

User Manual

Aegis Series Hybrid Inverter



Contents

1	Notes On This Manual	1	8	Start-Up And Shut Down The Inverter	21
1.1	Validity	1	8.1	Start-Up The Inverter	21
1.2	Target Group	1	8.2	Disconnecting The Inverter	21
1.3	Additional Information	1	9	Maintenance And Cleaning	21
1.4	Storage Of The Manuals	1	9.1	Checking Heat Dissipation	21
1.5	Symbols Used	2	9.2	Cleaning The Inverter	21
1.6	Markings On This Product	2	9.3	Checking The DC Switch	21
2	Safety And Conformity	3	10	Decommissioning	22
2.1	Safety Instructions	3	10.1	Dismantling The Inverter	22
3	Product Description	5	10.2	Packing The Inverter	22
3.1	Information Of The Unit	5	10.3	Storing The Inverter	22
3.2	Storage Of Inverter	6	10.4	Disposing Of The Inverter	22
4	Unpacking	7	11	Work Modes	23
5	Installation And Electrical Connection	8	12	Manufacturer Warranty	23
5.1	Safety	8	13	Technical Date	24
5.2	Selecting The Installation Location	9	14	Contact	26
5.3	Mounting The Inverter With Bracket	11			
5.4	Fixed The Inverter On The Wall	12			
5.5	Check Inverter Installation Status	13			
5.6	Electrical Connection	13			
5.6.1	Safety	13			
5.6.2	System Diagram With Inverter Electrical	13			
5.6.3	Connect To The Grid(AC Utility)	14			
5.6.4	Connect To The Back-up	15			
5.6.5	Connect To PV Panel	16			
5.6.6	Connect To The Battery	17			
5.6.7	Load Monitor Connect To The Inverter	19			
6	The Inverter Parameter setting	20			
7	Communications	20			
7.1	Wi-Fi	20			
7.2	The DRM0 Function For SAA Certification	20			

1 Notes On This Manual

1.1 Validity

This manual describes the assembly, installation, commissioning and maintenance of the Lantrun Aegis series hybrid inverter.

This manual does not cover any details concerning equipment connected to the unit (e.g. PV modules). Information concerning the connected equipment is available from the manufacturer of the equipment.

1.2 Target Group

 CAUTION	This manual has been developed for qualified personnel only who have received training and have demonstrated skills and knowledge in the construction and operation of this device. Qualified personnel are trained to deal with the dangers and hazards involved in installing electric devices.
---	---

1.3 Additional Information





Find further information on special topics at www.solarmonitorsystem.com.

1.4 Storage of the manuals







The manual and other documents must be stored in a convenient place and be available at all times. We assume no liability for any damage caused by failure to observe these instructions.

1.5 Symbols Used

The following types of safety instructions and general information appear in this document as described below:









 DANGER	Danger indicates a hazardous situation which, if not avoided, will result in death or serious injury.
 WARNING	WARNING indicates a hazardous situation which, if not avoided, could result in death or serious injury.
 CAUTION	CAUTION indicates a hazardous situation which, if not avoided, could result in minor moderate injury.
	Read the manual!
 NOTE	Failure to observe a warning indicated in this manual may lead to damage to property.

1.6 Markings On This Product

Symbol	Description
	Warning regarding dangerous voltage The product works with high voltage. All work on the product must only be performed as described in its documentation.
	Beware of hot surface The product can become hot during operation. Do not touch the product during operation.
	Observe the operating instructions Read the product's documentation before working on it. Follow all safety precautions and instructions as described in the documentation.
	Point of connection for grounding protection.
	Direct Current (DC)
	Alternating Current (AC)
	Signals danger due to electrical shock and indicates the time (5 minutes) to allow after the inverter has been turned off and disconnected to ensure safety in any installation operation.

2 Safety And Conformity

2.1 Safety Instructions

  DANGER	<p>Danger To Life Due To Lethal Voltages! Lethal voltages are present within the unit and on the power supply lines. Therefore, only authorized electricians may install and open the unit. Even when the unit is disconnected, high contact voltages may still be present within the unit.</p>
  DANGER	<p>Danger Of Burn Injuries Due To Hot Enclosure Parts! During operation, the four sides of the enclosure lid and the heat sink may become hot. Only touch the front enclosure lid during operation.</p>
  CAUTION	<p>Possible Damage To Health As A Result Of The Effects Of Radiation! In special cases, there may still be interference for the specified application area despite maintaining standardized emission limit values (e.g. when sensitive equipment is located at the setup location or when the setup location is near radio or television receivers). In this case, the operator is obliged to take proper action to rectify the situation. Do not stay closer than 20 cm to the inverter for any length of time.</p>
 NOTE	<p>Grounding The PV Generator Comply with the local requirements for grounding the PV modules and the PV generator. we recommends connecting the generator frame and other electrically conductive surfaces in a manner which ensures continuous conduction with ground these in order to have optimal protection of the system and personnel.</p>
 NOTE	<p>Capacitive Discharge Currents PV modules with large capacities relative to earth, such as thin-film PV modules with cells on a metallic substrate, may only be used if their coupling capacity does not exceed 470nF. During feed-in operation, a leakage current flows from the cells to earth, the size of which depends on the manner in which the PV modules are installed (e.g. foil on metal roof) and on the weather (rain, snow). This "normal" leakage current may not exceed 50mA due to the fact that the inverter would otherwise automatically disconnect from the electricity grid as a protective measure.</p>

DC and AC Breaker

Separate the unit securely from the grid and the PV, generators and battery using DC and AC breaker. DC and AC breaker shall be able to disconnect all non-ground conductors after installation.

Grounding The PV Modules

The unit is a transformerless inverter. That is why it has no galvanic separation. Do not ground the DC circuits of the PV modules connected to the unit. Only ground the mounting frame of the PV modules.

If you connect grounded PV modules to the unit the error message "PV ISO Low".

Qualification Of Skilled Workers

Only workers with the following skills should install this inverter:

- ▶ Knowledge of how an inverter works and is operated;
- ▶ Instructed in how to deal with the dangers and risks associated with installing and using electrical devices and plants;
- ▶ Training in the installation and commissioning of electrical devices and plants;
- ▶ Knowledge of all applicable standards and guidelines;
- ▶ Knowledge and observance of this manual and all safety instructions;

3 Product Description

3.1 Information Of The Unit

The unit is bidirectional which apply to PV system with battery to store energy. Energy produced by the PV system is used to optimize self-consumption; excess energy is used to charge the batteries, and then fed into the public grid when the PV energy is adequate.

When PV energy output is in sufficient to support connected loads, The system automatically get energy from the batteries if battery capacity is abundant. If the battery capacity is insufficient to meet own consumption requirements, electricity will be drawn from the public grid.

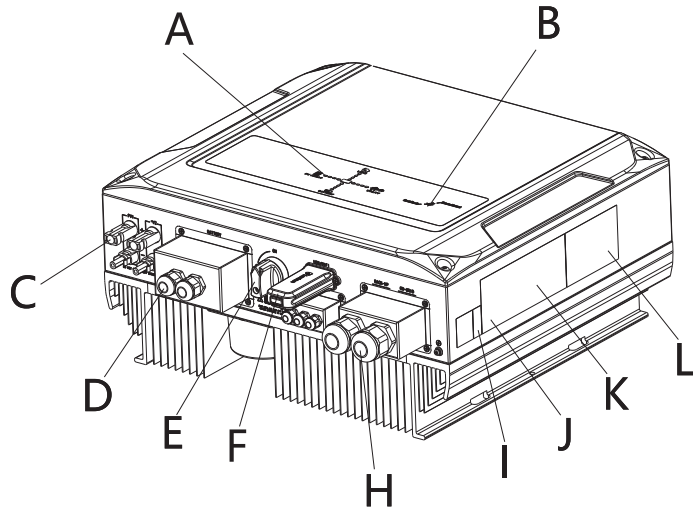

A	The Inverter Power Flow Direction Indicator
B	The Inverter Operation Status Indicator
C	PV Input Terminals
D	Battery Input Terminals And Cover
E	PV Input Switch
F	WIFI Com Module And USB Port
G	BAT._NTC and RS485 Communication (BMS Com, Load Monitor Com,)
H	AC Output Terminals And Cover
I	Inverter Serial No.
k	Spec Label
L	Warning Signals Label

3.2 Storage of Inverter

If you want to storage the unit in your warehouse, you should choose an appropriate location to store the inverter.

- ▶ The unit must be stored in original package and desiccant must be left in the package.
- ▶ The storage temperature should be always between -25°C and +60°C. And the storage relative humidity should be always between 0 and 95%Note; the battery storage much be according with the battery spec.
- ▶ If there are a batch of unit need to be stored, the maximum layers for original carton is four.

4 Unpacking

Thoroughly inspect the packaging upon received. If any damage to the carton is visible, or if you find that the unit is damaged after unpacking, please notify the shipping company and Sapphire Solar immediately.

Meanwhile please check the delivery for completeness and for visible external damages of the unit. If there are anything damaged or missing, please contact your dealer. Don't dispose its original package. If you want to transport the unit, it is better to store the unit into the original package.

Complete Delivery Should Contain As Follows:

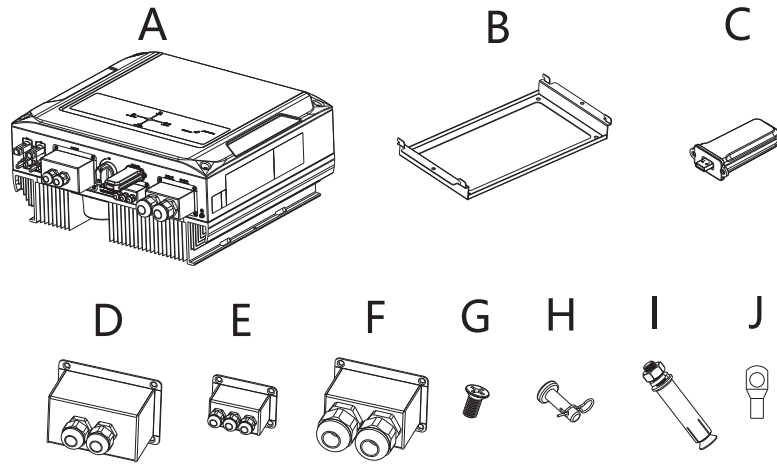

Item	Name	Quantity
A	Inverter	1
B	Mounting Frame	1
C	WIFI	1
D	BAT Wire Cover	1
E	BMS, RS485 Com Wire Cover	1
F	AC Output Cover	1
G	Cover Screw	14
H	Pin	2
I	Mounting Bracker Expansion Bolt	4
J	Battery Input Terminal	2

5 Installation And Electrical Connection

5.1 Safety

 DANGER	<p>Danger to life due to fire or explosion Despite careful construction, electrical devices can cause fires. Do not install the inverter on easily flammable materials and where flammable materials are stored.</p>
 DANGER	<p>Risk of burns due to hot enclosure parts Mount the inverter in such a way that it cannot be touched inadvertently.</p>
 DANGER	<ul style="list-style-type: none"> ▶ All electrical installations shall be done in accordance with the local and national electrical codes. Do not remove the casing. Inverter contains no user serviceable parts. Refer servicing to qualified service personnel. all wiring and electrical installation should be conducted by a qualified service personnel . ▶ Carefully remove the unit from its packaging and inspect for external damage. If you find any imperfections, please contact your local dealer. ▶ Be sure that the inverters connect to the ground in order to protect property and personal safety. ▶ The inverter must only be operated with PV generator. Do not connect any other source of energy to it. ▶ Both AC and DC voltage sources are terminated inside the PV Inverter. Please disconnect these circuits before servicing. ▶ This unit is designed to feed power to the public power grid (utility) only. Do not connect this unit to an AC source or generator. Connecting Inverter to external devices could result in serious damage to your equipment. ▶ When a photovoltaic panel is exposed to light, it generates a DC voltage. When connected to this equipment, a photovoltaic panel will charge the DC link capacitors. ▶ Energy stored in this equipment's DC link capacitors presents a risk of electric shock. Even after the unit is disconnected from the grid and photovoltaic panels, high voltages may still exist inside the PV-Inverter. Do not remove the casing until at least 5 minutes after disconnecting all power sources. ▶ Although designed to meet all safety requirements, some parts and surfaces of Inverter are still hot during operation. To reduce the risk of injury, do not touch the heat sink at the back of the PV-Inverter or nearby surfaces while Inverter is operating.

5.2 Selecting The Installation Location

This is guidance for installer to choose a suitable installation location, to avoid potential damages to device and operators.

- ▶ The unit shall be mounted at least 914 mm (3 feet) above the ground.
- ▶ The installation location must be suitable for the inverter's weight and dimensions for a long period of time.
- ▶ Select the installation location so that the status display can be easily viewed.
- ▶ Do not install the inverter on structures constructed of flammable or thermolabile materials.
- ▶ The humidity of the installation location should be 0~95% without condensation.
- ▶ The installation location must be free and safe to access at all times.
- ▶ Installation must be vertical or tilted backwards by max. 15° and make sure the connection of the inverter is downwards. Never install horizontally. Avoid forward or sideways tilt.
- ▶ Be sure that the inverter is out of children's reach.
- ▶ Don't put anything on top of or cover the inverter.
- ▶ Do not install the inverter near television antennae or any other antennae/antennae cables.
- ▶ The inverter requires adequate cooling space. Ensure good ventilation for the inverter to ensure the heat escape adequately. The ambient temperature should be below 40°C to ensure optimum operation.

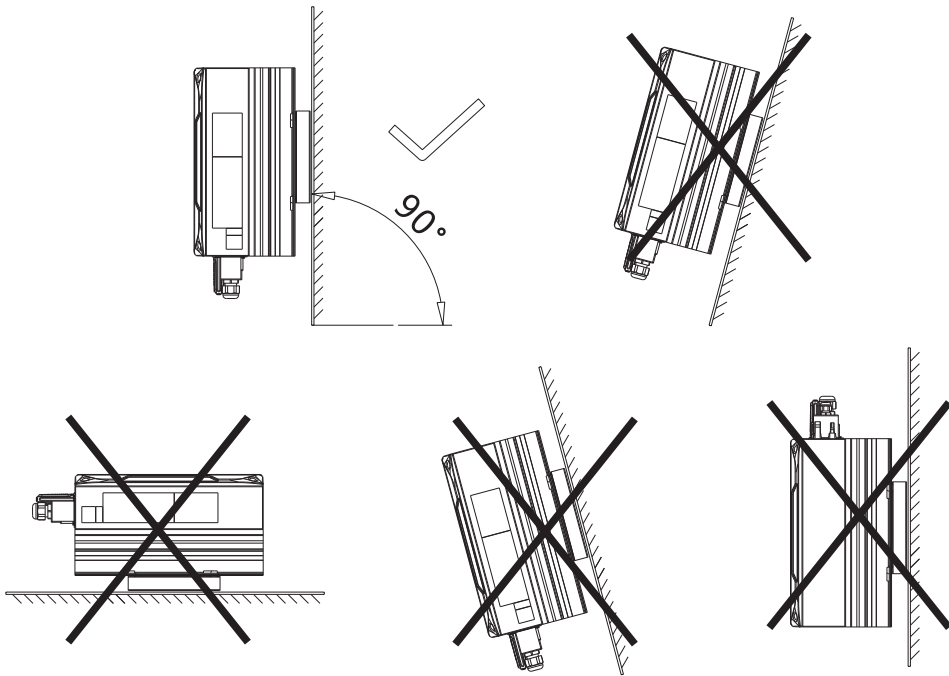

9

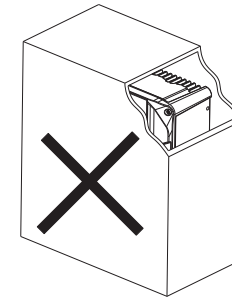

- ▶ The inverter should not be installed in direct sunlight and should have some coverage from the elements:



- ▶ Observe the minimum clearances to walls, other inverters or objects as shown in the diagram below in order to guarantee sufficient heat dissipation.

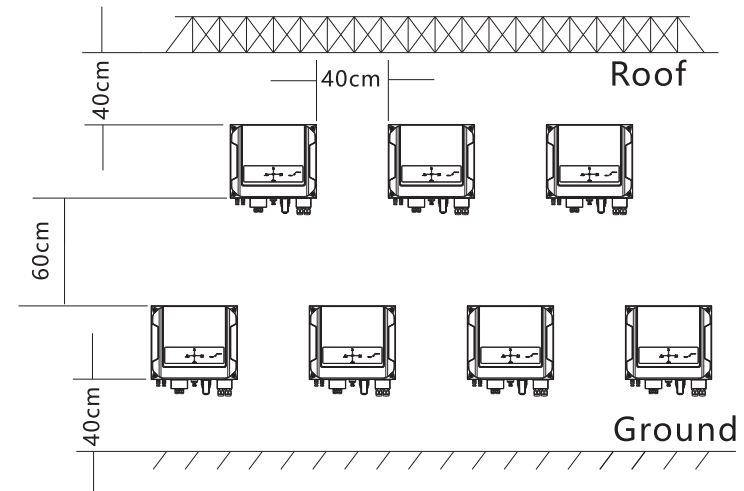

10

Ambient Dimensions Of A Series Inverters

- ▶ There must be sufficient clearance between the individual inverters to ensure that the cooling air of the adjacent inverter is not taken in.
- ▶ If necessary, increase the clearance spaces and make sure there is enough fresh air supply to ensure sufficient cooling of the inverters.

5.3 Mounting The Inverter With Bracket

 WARNING	In order to avoid electrical shock or other injury, inspect existing electronic or plumbing installations before drilling holes.
--	--

- ▶ The dimension of bracket as follow:

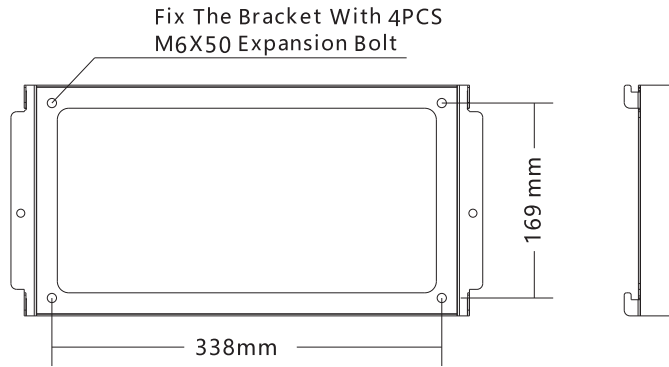

- ▶ Using the mounting frame as a template, drill holes as illustrated in image. Fix the mounting frame as the figure shows. Do not make the screws to be flush to the wall. Instead, leave 2 to 4mm exposed.

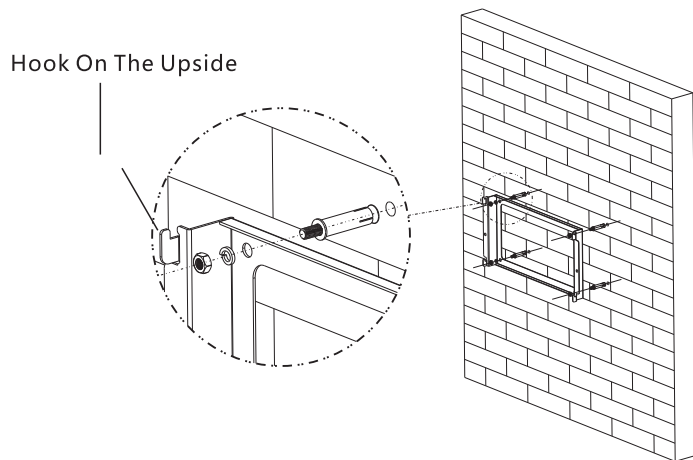

5.4 Fixed The Inverter On The Wall

 WARNING	Falling equipment can cause serious or even fatal injury, never mount the inverter on the bracket unless you are sure that the mounting frame is firmly mounted on the wall after cautious checking.
--	--

- ▶ Raise the inverter a little higher than the bracket whilst maintaining the balance of the inverter.
Hang the inverter on the bracket through the match hooks on bracket.

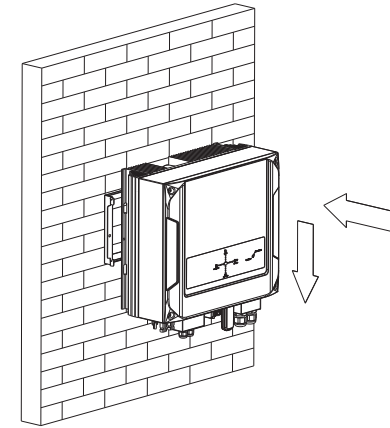

- ▶ After confirming the inverter is fixed reliably, insert the pins into the holes as the figure shows, prevent the inverter from being lifted off the bracket.

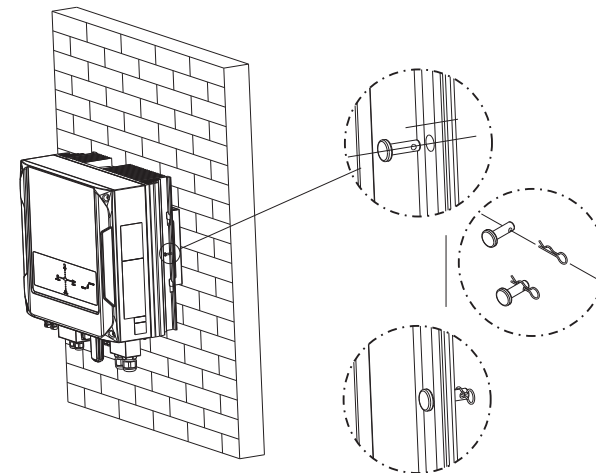





5.5 Check Inverter Installation Status

- ▶ Check the upper straps of inverter and ensure it fits on to the bracket.
- ▶ Check the secure mounting of the inverter by trying to raise it from the bottom. The inverter should remain firmly attached.
- ▶ Choose a strong mounting wall to prevent vibration while inverter is operating.

5.6 Electrical Connection

5.6.1 Safety

  DANGER	<p>Danger To Life Due To Lethal Voltages!</p> <p>High voltages which may cause electric shocks are present in the conductive parts of the inverter. Prior to performing any work on the inverter, disconnect the inverter on the AC side, PV side, battery side. Do not reverse input the battery as this will destroy the inverter!</p>
 WARNING	<p>Danger Of Damage To Electronic Components Due To Electrostatic Discharge.</p> <p>Take appropriate ESD precautions when replacing and installing the inverter.</p>
 DANGER	<p>Grounding.</p> <p>Before connecting the power cables, you must connect ground wire first.</p>

5.6.2 System Diagram With Inverter Electrical

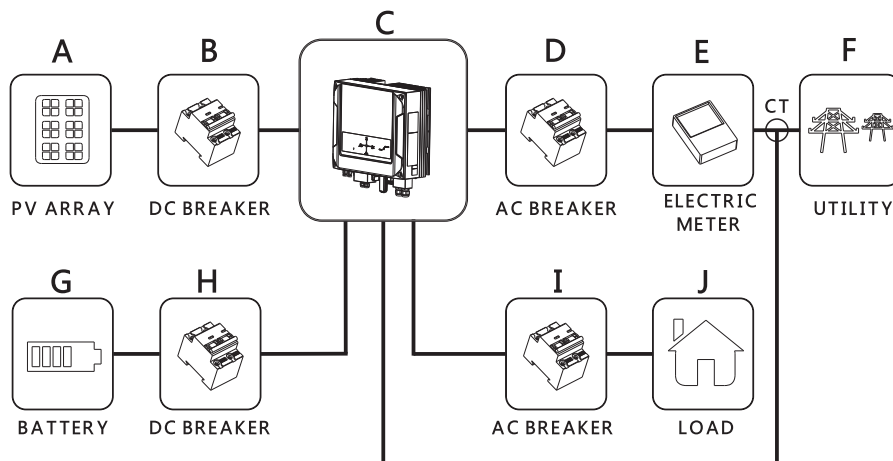

Position	Description
A	PV Modules
B	PV Side Breaker
C	Inverter
D	Main AC Output Breaker
E	Electric Meter
F	Utility Grid
G	Battery
H	Battery DC Breaker
I	Back-up Output Breaker(max.2500VA)
J	Important Load(max.2500VA)

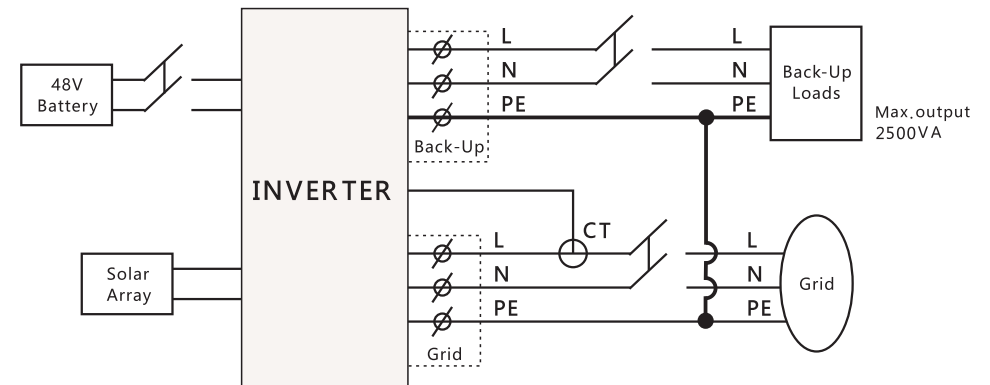

5.6.3 Connect To The Grid (AC Utility)

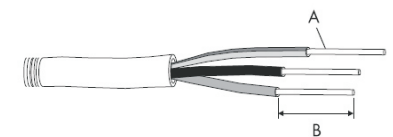
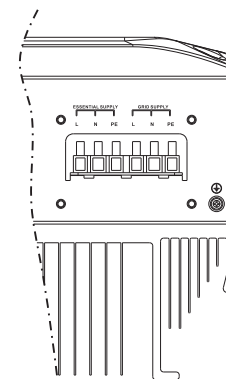



A Conductor Cross-section:
See the conductor cross section in the flowing chart

B Bare Length: 8mm around

Output cable requirements

Product Model	Current	Area(mm ²)	AWG No.
Aegis 3600ES	25A	5.26 ~9.0	8 ~10
Aegis 4600ES	32A	5.26 ~9.0	8 ~10
Aegis 5000ES	32A	5.26 ~9.0	8 ~10

 NOTE	<ul style="list-style-type: none"> ▶ Use only solid or stranded wire but not fine stranded wire. ▶ Use cables with high ambient temperatures. ▶ Use cables with a large cross-section. ▶ The cable length should not exceed 50 m as the resistance of the cable will consume inverter output power and reduce the inverter efficiency.
 WARNING	<ul style="list-style-type: none"> ▶ You must install a separate AC circuit-breaker or other load disconnection unit between the inverter and utility, in order to ensure that the inverter can be safely disconnected under load. ▶ The separate disconnection unit has below requirement: Voltage: the voltage must not be less than the AC grid voltage which you connect. Current: the current must not be less than 1.2 times of the inverter max output current which defined in the inverter spec.

5.6.4 Connect To The Back-up

The back-up can provide max output power 2500VA and you can connect the important load to the back-up terminal, however you must install a AC separate circuit-breaker or other load disconnection unit between the inverter back-up output and the important load, in order to ensure that the inverter can be safely disconnected under load. We suggest the separate unit spec is **20A**.

 WARNING	<p>The back-up MAX output power is 2500VA, if the load greater than 2500VA, and after 3 times of inverter checking, the inverter will stop to output. The output power of back-up also depends on the battery capacity.</p>
---	---

5.6.5 Connect To PV Panel

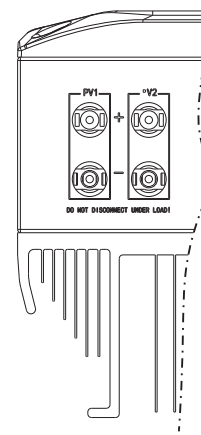

PV Input Connection Terminal

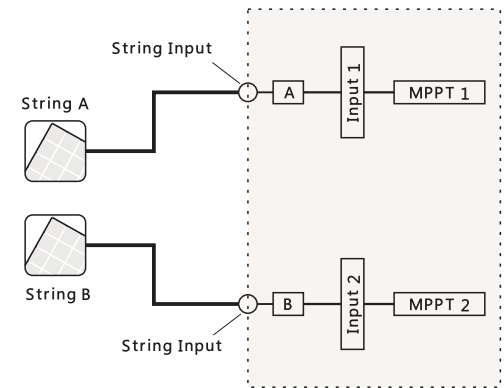

There are two MPP trackers built in to the unit, so you can connect two independent MPP channels.

Output cable requirements

Product Model	Current	Area(mm ²)	AWG No.
Aegis 3600ES	25A	5.26 ~9.0	8 ~10
Aegis 4600ES	32A	5.26 ~9.0	8 ~10
Aegis 5000ES	32A	5.26 ~9.0	8 ~10

▶ Suggestions for the PV modules of the connected strings:

- ◆ Same type
- ◆ Same quantity of PV modules connected in series

▶ Under all conditions ! Make sure the maximum open circuit voltage (Voc) of each PV string is less than 600Vdc.

- ◆ Do not connect strings with an open circuit voltage greater than the maximum input voltage of the inverter. If the strings voltage exceeds the maximum input voltage of the inverter, the inverter can be destroyed due to overvoltage. All warranty claims become void.
- ◆ Check the design of the PV plant. The max. open circuit voltage, which can occur at solar panels ambient temperature of -10°C, must not exceed the max. input voltage of the inverter.

▶ Before connecting PV panels to DC terminals, please make sure the polarity is correct. Incorrect polarity connection could permanently damage the unit.

▶ Check short-circuit current of the PV string. The total short-circuit current of the PV string should be less than the inverter's maximum DC current.

- ▶ Connect the positive and negative terminals from the PV panel to positive (+) terminals and negative (-) terminals on the PV-Inverter. Each DC terminal on Inverter can withstand 11A.
 - ◆ For instance, if the positive pole of a string is connected at MPP tracker A and the string's negative pole at MPP tracker B, this is called a mixed connection, the inverter no longer fulfils the requirements of the EMC Directive.
 - ◆ Only connect strings at one input zone and never mix the input zones A and B.
 - ◆ High voltages exist when the PV panel is exposed to the sun. To reduce risk of electric shock, avoid touching live components and treat connection terminals carefully.

 DANGER	<ul style="list-style-type: none"> ▶ Risk of electric shock and fire, use only with PV modules, and with a maximum system voltage of 600Vdc. ▶ Electric shock hazard, the DC conductors of this PV system are normally ungrounded but will become intermittently grounded without indication when the inverter detects the PV array isolation. Because of the transformerless design, the DC positive pole and DC negative pole of PV arrays are not permitted to be grounded. ▶ Do not disconnect the DC connectors under load.
--	---

5.6.6 Connect To The Battery

- ▶ Before connecting to the battery, you must install a separate DC breaker (not less than 120A) between the inverter and battery that will ensure the inverter can be securely disconnected during maintenance.

 DANGER	<h2>Reversed polarity will damage the inverter!!!</h2>
---	--

- ▶ It is very important for system safety and efficient operation to use appropriate cable for battery connection. To reduce risk of injury, you must use the recommended cable size, refer to the below chart;

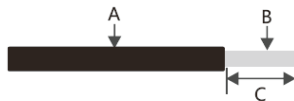

Grade	Description	Value
A	O.D.	10 ~ 12mm
B	Conductor Material Sectional Area	20 ~ 25mm ²
C	Bare Wire Length	10mm around



- ▶ The battery installation must comply with the manufacturer's user manual, include installing indoor or outdoor and the distance to the inverter.
- ▶ The maximum charge/discharge current is 50A of the inverter, check the battery current in the spec.
- ▶ As the inverter's battery rated voltage is 48V, the battery series connection voltage must not exceed 48V or it will damage the inverter.

The following steps must be adhered to in order to implement the battery connection:

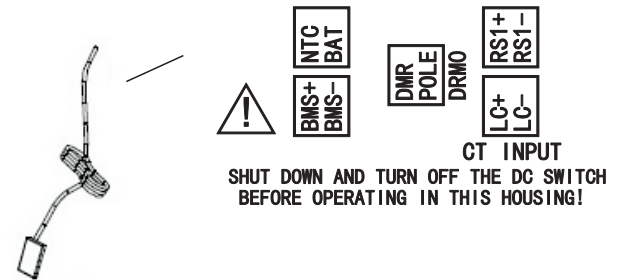
- (1) Disconnect the breaker between inverter and battery;
- (2) Check the polarity of the battery and the inverter;
- (3) Compress the terminal head by professional tool;
- (4) Screw the wire cable to the inverter's battery input terminal;
- (5) If the inverter connects to a lead-acid type battery, you must connect BAT.NTC to the inverter, the connection terminal in the COM connection port. (see diagram below);



- (6) If the inverter connects to a lithium battery, you must connect the BMS to the BMS -RS485 com.

 NOTE	<p>we recommend using the Sapphire Solar appointed lithium battery, because the battery BMS communication has been designed to be compatible with the Sapphire Solar Gem Series Hybrid Inverter.</p>
 DANGER	<h3>Danger to life due to voltages!</h3> <p>Before you install the BAT.NTC, you must turn off the inverter, check all the separate breakers are off, and the inverter's LED is off. Then you can safely install the BAT.NTC terminal to the inverter.</p>

5.6.7 Load Monitor Connect To The Inverter

In the system, a CT must be installed to monitor the power of the house to decide the inverter status: charge or discharge. The load monitor module is for this purpose.

The load monitor input is 230Vac/ 50Hz. You can connect to the grid. The CT must be installed at the beginning from the grid to the house, in this case, the inverter can monitor all household consumption of power. According to the sensor, the inverter will control the PV power feeding to the grid to balance the level of household power use.

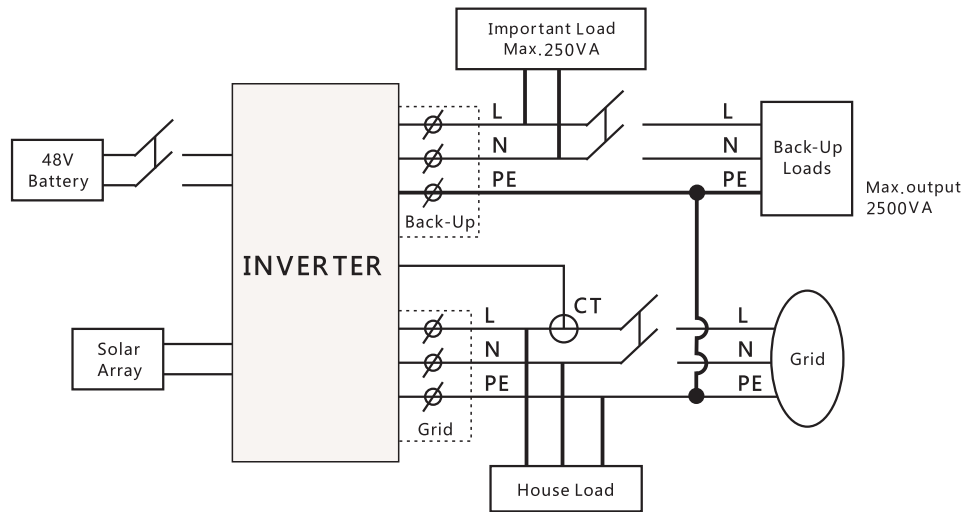

The CT installation directions are as follows:

- ◆ The direction of the CT mark "K" arrow is point to the GRID!
- ◆ And the load monitor communication to the inverter via RS 485

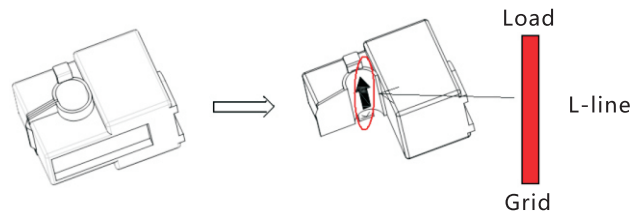

	NOTE
Check the RS+ and RS- signal wiring is correct!	
	WARNING
The load monitor input L-line must be the same as the CT sensor L-line, and the input of the load monitor L&N cannot reverse. If this occurs the inverter will do the reverse direction power control, which means PV power will not store to the battery and the battery cannot discharge the power to the house load.	

6 The Inverter Parameter Setting

With the Wi-Fi app, you can go through the local mode to set up the battery parameters, and the grid charging time, inverter discharging time etc. If you are not setting parameters, the inverter will work in default mode.

	WARNING
Ensure that all wire connections are OK before turning on the battery breaker and the AC breaker. The PV switch should be turned on first to light the inverter and the battery parameters must be set according to your battery system and work status times. Otherwise the inverter will work at default status that may not conform to the battery voltage and the capacity.	

7 Communications

7.1 Wi-Fi

Aegis series of inverter use Wi-Fi as standard wireless communication. Please reading the Wi-Fi module's User Manual first, or visiting our website for relative information.

7.2 The DRM0 Function For SAA Certification

The DRM0 function of Aegis ES series inverter be provided for SAA. The DRM0 connection CN5 in the front plate, as the picture:

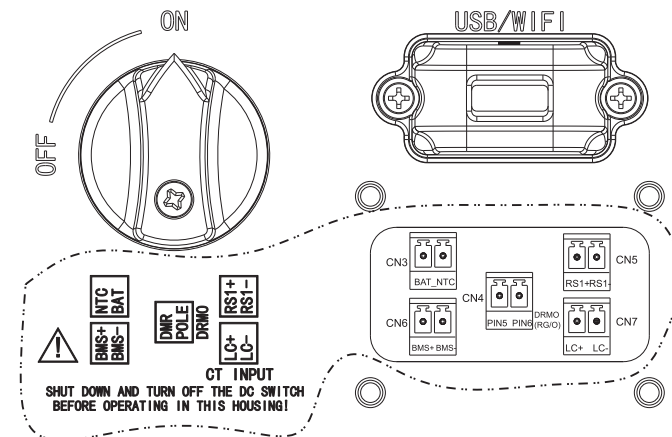

When receive the order from DRM0 connection, the inverter will acting responding to the order, the inverter must POWER OFF or POWER ON.

8 Start-Up And Shut Down The Inverter

8.1 Start-Up The Inverter

- (1) Connect the AC circuit breaker;
- (2) Turn on the DC switch;
- (3) Turn on the battery breaker;
- (4) The inverter will start automatically when the PV voltage is higher than 150V and the battery voltage is higher than ;

8.2 Disconnecting The Inverter

- (1) Disconnect the AC circuit breaker and prevent it from being reactivated;
- (2) Disconnect the Battery breaker and prevent it from being reactivated;
- (3) Turn off the PV switch;
- (4) Check the inverter operating status;
- (5) Wait until LED display has gone out, this will indicate the inverter is shut down;

9 Maintenance And Cleaning

9.1 Checking Heat Dissipation

If the inverter regularly reduces its output power due to high temperature, please improve the heat dissipation conditions. The heat sink may need to be cleaned as part of this process.

9.2 Cleaning The Inverter

If the inverter is dirty, shut down the inverter, then clean the enclosure lid.

9.3 Checking The DC Switch

Check for externally visible damage and discoloration of the breaker and the cables at regular intervals. If there is any visible damage to the breaker, or visible discoloration or damage to the cables, contact the local Sapphire Solar Partner.



WARNING

Once a year, turn the rotary switch of the DC switch from the ON position to the OFF position 5 times in succession. This cleans the contacts of the rotary switch and prolongs the electrical endurance of the DC Disconnect.

10 Decommissioning

10.1 Dismantling The Inverter

- (1) Disconnect the inverter as described;
- (2) Remove all connection cables from the inverter;
- (3) Screw off all projecting cable glands;
- (4) Lift the inverter off the bracket and unscrew the bracket screws;



Danger of burn injuries due to hot enclosure parts!
Wait 20 minutes before disassembling until the housing has cooled down.

10.2 Packing The Inverter

If possible, always pack the inverter in its original carton and secure it with tension belts. If it is no longer available, you can also use an equivalent carton. The box must be capable of being closed completely and supporting both the weight and the size of the inverter.

10.3 Storing The Inverter

Store the inverter in a dry place where ambient temperatures are always between -25°C and $+60^{\circ}\text{C}$.

10.4 Disposing Of The Inverter



Do not dispose of faulty inverters or accessories together with household waste. Please comply with the disposal regulations for electronic waste which apply at the installation site at that time. Ensure that the old unit and any accessories are disposed of in a proper manner.

11 Work Modes

The Sapphire Solar Gem Series Hybrid Inverter has the following main work modes:

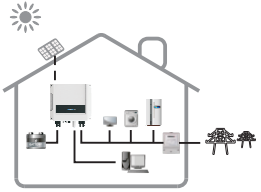
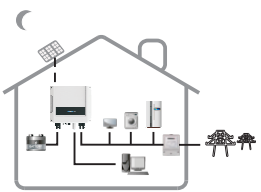
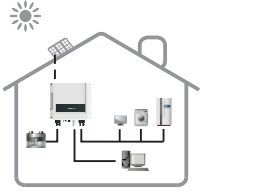
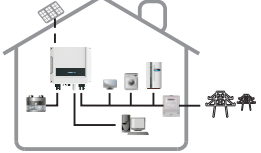
<p>Mode1: Energy Produced by the PV system is preferred for local load. And the excess energy is first used for charging batteries, then feeding to the grid.</p>	
<p>Mode2: IF there is no PV, battery energy is used for local load first, the grid also can supply when the battery capacity is not enough.</p>	
<p>Mode3: If the grid is fault or there is no grid, the system can still work, PV and batteries supply energy for local load.</p>	
<p>Mode4: The battery can be charged by the grid, time and power of battery charging can be set up flexibly.</p>	

12 Manufacturer Warranty

Sapphire Solar Gem series hybrid Inverters come with a 5 year warranty from the date of commissioning. please refer to the Sapphire Solar Warranty Terms accompanying this manual or download them from www.solarmonitorsystem.com.

13 Technical Data

SPEC	Aegis 3600ES	Aegis 4600ES	Aegis 5000ES
Input Date (DC)			
Max. DC Power	3800W	5000W	5400W
Max. DC Voltage	600V		
Start Voltage	100V		
DC Nominal Voltage	360V		
PV Voltage Range	100V ~ 600V		
MPP Voltage Range	120V ~ 550V		
Max. input Current Tacker A/ B	11A/11A		
Number Of Independent MPP Input	2		
Output Date (AC)			
Nominal AC Output Power	3600W	4600W	5000W
Max.AC Apparent Power	3600VA	4600VA	5000VA
Max.Output Current	16.4A	21.0A	22.8A
AC Nominal Voltage; Range	220V/230V/240V; 180Vac~280Vac		
AC Grid Frequency; Range	50,60Hz; ±5Hz		
Power factor at rate power	1		
Power Factor	0.8leading...0.8lagging		
THDi	<3%		
AC connection	Single phase		
Battery			
Battery Type	Lead-acid or Li-ion		
Norminal voltage	48V		
Battery Capacity	> =100Ah(depending requirement)		
Energy	5.0kWh(depending requirement)		
Max. discharging /Charging Power	2500W / 2500W		
Charging Curve	3-stage adaptive with maintenance		
Operating Voltage Range	46.4-57.6V		
Max. Charging/Discharging Current	50A / 50A		
Backup Output			
Output Rate Power	2300VA		
Peak Power	3450VA, 10s		
Output Voltage	230Vac ±2% 50/60Hz±0.2%, THDV<3%		
Efficiency			
Max. efficiency	97%	97.10%	97.10%
Euro - eta	96.50%	96.50%	96.50%
MPPT efficiency	99.50%	99.50%	99.50%

SPEC	Aegis 3600ES	Aegis 4600ES	Aegis 5000ES
Protection Devices			
DC reverse polarity protection	Yes		
DC switch rating for each MPPT	Yes		
Output over current protection	Yes		
Output overvoltage protection-varistor	Yes		
Ground fault monitoring	Yes		
Grid monitoring	Yes		
Max. inrush current	30A peak		
Max. output fault current	40A peak		
Max. output overcurrent protection	25A rms		
Integrated all - pole sensitive leakage current monitoring unit	Yes		
General Data			
Dimensions (W / H / D)	480 X 410 X 220mm		
Weight	27.2KG	27.4KG	27.8KG
Operating temperature range	-25...+60°C (-13...+ 140°F) With derating above 45°C (113°F)		
Noise emission (typical)	≤ 25 dB(A)		
Altitude	Up to 2000m (6560ft) Without power derating		
Relative humidity	95%		
Consumption: operating (standby) / night	<5W / < 0.5 W		
Topology	Transformerless		
Cooling concept	Natural		
Environmental Protection Rating	IP65		
Features			
PV connection	H4/MC4		
Battery connection	Screw terminal		
AC connection	Screw terminal		
Display	LED		
Interfaces: Wi-Fi/USB/GPRS/RS485	Yes/Yes/Opt/Opt		
Warranty:	5 years		
Certificates and approvals	CE, IEC 62109-1&2, VDE 0126-1-1 G83/2, As4777&NZS 3100		

Note:

- (1) Backup output power depends on of the battery.
- (2) Specifications are subject to change without further notice.

14 Contact

Please contact your local Sapphire Solar Partner if you need technical support. You may need to provide the following information:

- (1) Item No. of inverter;
- (2) Product series;
- (3) Error code and description;
- (4) Configuration of your system;

技术要求:

1: 材质:封面: 105克铜板CMYK印刷, 内页80克书写纸黑白印刷

2: 装订后成品尺寸:142*210mm(公差+/-2MM);

3: 印刷效果:图片、字体、线条需清晰,无重影,无毛边,无多余杂点;